

TREADMILL DESK

Operation Manual



CORPORATE HEADQUARTERS

Columbia Centre III, 9525 West Bryn Mawr Avenue, Rosemont, Illinois 60018 • U.S.A.

847.288.3300 • FAX: 847.288.3703

Service phone number: 800.351.3737 (toll-free within U.S.A., Canada)

Global Website: www.lifefitness.com

INTERNATIONAL OFFICES

AMERICAS

North America Life Fitness, Inc.

Columbia Centre III
9525 West Bryn Mawr Avenue
Rosemont, IL 60018 U.S.A
Telephone: (847) 288 3300
Fax: (847) 288 3703
Service Email:
customersupport@lifefitness.com
Service Website: www.lifefitness.com/parts
Sales/Marketing Email:
commercialsales@lifefitness.com
Operating Hours: 7:00 am-6:00 pm (CST)

Brazil Life Fitness Brasil

Av. Cidade Jardim, 900
Jd. Paulistano
São Paulo, SP 01454-000
BRAZIL
SAC: 0800 773 8282
Telephone: +55 (11) 3095 5200
Fax: +55 (11) 3095 5201
Service Email: suporte@lifefitness.com.br
Sales/Marketing Email:
lifefitness@lifefitness.com.br
Service Operating Hours:
9:00 - 17:00 (BRT) (Monday-Friday)
Store Operating Hours:
9:00 -20:00 (BRT) (Monday-Friday)
10:00 - 16:00 (BRT) (Saturday)

Latin America & Caribbean* Life Fitness Inc.

Columbia Centre III
9525 West Bryn Mawr Avenue
Rosemont, IL 60018 U.S.A
Telephone: (847) 288 3300
Fax: (847) 288 3703
Service Email:
customersupport@lifefitness.com
Sales/Marketing Email:
commercialsales@lifefitness.com
Operating Hours: 7:00am-6:00pm (CST)

EUROPE, MIDDLE EAST, & AFRICA

(EMEA)

Netherlands & Luxemburg Life Fitness Atlantic BV

Bijdorpplein 25-31
2992 LB Barendrecht
THE NETHERLANDS
Telephone: (+31) 180 646 666
Fax: (+31) 180 646 699
Service Email:
service.benelux@lifefitness.com
Sales/Marketing Email:
marketing.benelux@lifefitness.com
Operating Hours: 9.00h-17.00h (CET)

United Kingdom & Ireland Life Fitness UK LTD

Queen Adelaide
Ely, Cambs, CB7 4UB
Telephone: General Office (+44)
1353.666017
Customer Support (+44) 1353.665507
Fax: (+44) 1353.666018
Service Email: uk.support@lifefitness.com
Sales/Marketing Email: life@lifefitness.com
Operating Hours:
General Office: 9.00am - 5.00pm (GMT)
Customer Support: 8.30am - 5.00pm
(GMT)

Germany & Switzerland Life Fitness Europe GMBH

Siemensstraße 3
85716 Unterschleißheim
GERMANY
Telephone: (+49) 89.31 77 51.0 (Germany)
(+41) 0848 000 901 (Switzerland)
Fax: (+49) 89.31 77 51.99 (Germany)
(+41) 043 818 07 20 (Switzerland)
Service Email:
kundendienst@lifefitness.com
Sales/Marketing Email:
kundenberatung@lifefitness.com
Operating Hours: 08.30 -16.30h (CET)

Austria Life Fitness Austria

Vertriebs G.m.b.H.
Dückerstraße 7-9/3/36
1220 Vienna
AUSTRIA
Telephone: (+43) 1.61.57.198
Fax: (+43) 1.61.57.198.20
Service Email: kundendienst@lifefitness.com
Marketing/Sales Email:
kundenberatung@lifefitness.com
Operating Hours: 08:30-16.30.h (MEZ)

Spain Life Fitness IBERIA

C/Frederic Mompou 5,1ª^a
08960 Sant Just Desvern Barcelona
SPAIN
Telephone: (+34) 93.672.4660
Fax: (+34) 93.672.4670
Service Email: servicio.tecnico@lifefitness.com
Sales/Marketing Email:
info.iberia@lifefitness.com
Operating Hours:
9.00h-18.00h (Monday-Thursday)
8.30h-15.00h (Friday)

Belgium Life Fitness Benelux NV

Parc Industriel de Petit-Rechain
4800 Verviers
BELGIUM
Telephone: (+32) 87 300 942
Fax: (+32) 87 300 943
Service Email:
service.benelux@lifefitness.com
Sales/Marketing Email:
marketing.benelux@lifefitness.com
Operating Hours: 9.00h -17.00h (CET)

All Other EMEA Countries & Distributor Business C-EMEA*

Bijdorpplein 25-31
2992 LB Barendrecht
THE NETHERLANDS
Telephone: (+31) 180 646 644
Fax: (+31) 180 646 699
Service Email:
service.db.cemea@lifefitness.com
Sales/Marketing Email:
marketing.db.cemea@lifefitness.com
Operating Hours: 9.00h-17.00h (CET)

ASIA PACIFIC (AP)

Japan Life Fitness Japan

Japan Nippon Brunswick Bldg., #8F
5-27-7 Sendagaya
Shibuya-Ku, Tokyo
Japan 151-0051
Telephone: (+81) 3.3359.4309
Fax: (+81) 3.3359.4307
Service Email: service@lifefitnessjapan.com
Sales/Marketing Email:
sales@lifefitnessjapan.com
Operating Hours: 9.00h-17.00h (JAPAN)

China and Hong Kong Life Fitness Asia Pacific LTD

Room 2610, Miramar Tower
132 Nathan Road
Tsimshatsui, Kowloon
HONG KONG
Telephone: (+852) 2891.6677
Fax: (+852) 2575.6001
Service Email:
HongKongEnquiry@lifefitness.com
Sales/Marketing Email:
ChinaEnquiry@lifefitness.com
Operating Hours: 9.00h-18.00h

All Other Asia Pacific countries & distributor business Asia Pacific*

Room 2610, Miramar Tower
132 Nathan Road
Tsimshatsui, Kowloon
HONG KONG
Telephone: (+852) 2891.6677
Fax: (+852) 2575.6001
Service Email:
HongKongEnquiry@lifefitness.com
Sales/Marketing Email:
ChinaEnquiry@lifefitness.com
Operating Hours: 9.00h-18.00h

* Also check www.lifefitness.com for local representation or distributor/dealer

Table of Contents

1	SAFETY INSTRUCTIONS	5
2	TREADMILL DESK ILLUSTRATION	7
3	SETUP	8
4	INTEGRATED CONSOLE DISPLAY & USER CONTROLS	11
5	BACK LEDGE CONNECTION & ATTACHMENT OPTIONS	13
6	ERGONOMICS	14
7	SETTINGS & DIAGNOSTICS MENU	15
8	SERVICE & TECHNICAL DATA	16
8.1	TROUBLESHOOTING	16
8.2	PREVENTIVE MAINTENANCE TIPS	17
8.3	HOW TO ADJUST AND TENSION THE WALKING BELT ON THE TREADMILL DESK	18
8.4	TRACKING (CENTERING) A NEW WALKING BELT	19
8.5	USING AND TESTING THE SAFETY STOP PULL CORD	19
8.6	HOW TO OBTAIN PRODUCT SERVICE	19
9	SPECIFICATIONS	20
10	WARRANTY	21

© 2015 Life Fitness, a division of Brunswick Corporation. All rights reserved. Gym Wipes® is a registered trademark of The 2XL Corporation. PureGreen 24 is a trademark of Pure Green.

Before using this product, it is essential to read this ENTIRE operation manual and ALL installation instructions. It describes equipment setup and instructs members on how to use it correctly and safely.

Avant d'utiliser ce produit, il est indispensable de lire ce manuel d'utilisation dans son INTÉGRALITÉ, ainsi que TOUTES les instructions d'installations. Ce manuel explique comment installer l'équipement et comment l'utiliser correctement et sans danger.

Note: *This equipment has been tested and found to comply with the limits for a Class A digital device, pursuant to part 15 of the FCC rules. These limits are designed to provide reasonable protection against harmful interference when the equipment is operated in a commercial environment. This equipment generates, uses and can radiate radio frequency energy, and if not installed and used in accordance with the instruction manual, may cause harmful interference to radio communications. Operation of this equipment in a residential area is likely to cause harmful interference in which case the user will be required to correct the interference at his own expense.*



CAUTION: Any changes or modifications to this equipment could void the product warranty.

Mise en garde : tout changement ou toute modification de ce matériel peut annuler la garantie du produit.

Any service, other than cleaning or user maintenance, must be performed by an authorized service representative.

This Operation Manual describes the functions of the following product:

Treadmill Desk

See "Specifications" in this manual for product specific features.

Statement of Purpose: The Treadmill Desk is an exercise machine that enables users to walk in place on a moving surface.

Life Fitness **STRONGLY** recommends seeing a physician for a complete medical exam before undertaking an exercise program, particularly if the user has a family history of high blood pressure or heart disease, is over the age of 45, smokes, has high cholesterol, is obese, or has not exercised regularly in the past year.

If, at any time while exercising, the user experiences faintness, dizziness, pain, or shortness of breath, he or she must stop immediately.

Life Fitness recommande **FORTEMENT** de consulter un médecin pour subir un examen médical complet avant de commencer tout programme d'exercice, et tout particulièrement si l'utilisateur a des antécédents familiaux d'hypertension ou de troubles cardiaques, s'il a plus de 45 ans, s'il fume, s'il a du cholestérol, s'il est obèse ou n'a pas fait d'exercice régulièrement depuis un an.

Si, pendant l'utilisation de l'appareil, l'utilisateur ressent un malaise, des vertiges, des douleurs ou des vertiges, des douleurs ou des difficultés à respirer, il doit s'arrêter immédiatement.

1 IMPORTANT SAFETY INSTRUCTIONS

Read all instructions before using the Treadmill Desk.



DANGER: To reduce the risk of electrical shock, always unplug Life Fitness products before cleaning or attempting any maintenance activity.

- **WARNING:** To reduce the risk of burns, fire, electric shock, or injury, it is imperative to connect each product to a properly grounded electrical outlet. See *Grounding Instructions*.
- **WARNING:** Over exercising may result in serious injury or death. If you feel faint, stop exercising immediately.
- **WARNING:** The ASTM International (ASTM) F2115 - 05 Standard recommends the minimum dimensions to be 1.64 ft. (0.5 m) on each side of the treadmill and 3.28 ft. (1 m) behind the rearward most portion of the usable moving surface.
- **WARNING:** Be sure the emergency stop lanyard is clipped to the user and in proper position on the Treadmill Desk before beginning any session.
- **WARNING:** The belt centering adjustment must be performed if the belt is not between the marks indicating the maximum allowed lateral positions. Refer to Section 3.
- **WARNING:** The Treadmill Desk has immobilization lockout software. Activate the software lockout when the Treadmill Desk is not in use. Refer to *Immobilizing the Treadmill Desk* in Section 3 for information on how to immobilize the Treadmill Desk. Keep the instructions out of the reach of children.
- **CAUTION:** Risk of injury to persons - to avoid injury, use extreme caution when stepping onto or off of a moving belt. Read instruction manual before using.
- **CAUTION:** Any changes or modifications to this equipment could void the product warranty.
 - To disconnect, turn power OFF at the ON/OFF switch, then remove plug from electrical outlet.
 - The product should never be left unattended when plugged in. Disconnect from the electrical outlet when not in use, and before putting on or taking off parts. To disconnect, turn power OFF on the ON/OFF switch, then remove plug from electrical outlet.
 - Never operate a Life Fitness product if it has a damaged power cord or electrical plug, or if it has been dropped, damaged, or even partially immersed in water. Contact Life Fitness Customer Support Services.
 - Position the product so that the power cord plug to the wall is accessible to the user. Make sure that the power cord is not knotted or twisted and that it is not trapped under any equipment or other objects.
 - If the electrical supply cord is damaged, it must be replaced by the manufacturer, an authorized service agent, or a similarly qualified person to avoid a hazard.

- Always follow the console instructions for proper operation.
- This appliance is not intended for use by persons (including children) with reduced physical, sensory, or mental capabilities, or lack of experience or knowledge unless they have supervision or been given instruction concerning the use of the appliance by a person responsible for their safety.
- Children should be supervised to ensure that they do not play with the product.
- Do not use this product outdoors, near swimming pools or in areas of high humidity.
- Never operate a Life Fitness product with the air openings blocked. Keep air openings free of lint, hair, or any other obstructing material.
- Never insert objects into any opening in these products. If an object should drop inside, turn off the power, unplug the power cord from the outlet, and carefully retrieve it. If the item cannot be reached, contact Life Fitness Customer Support Services.
- Containers with lids are recommended if placing liquids on the unit.
- Do not use the actuator system for lifting persons. Do not sit or stand on a table while operating - risk of personal injury.
- Do not use these products in bare feet. Always wear shoes. Wear shoes with rubber or high-traction soles. Do not use shoes with heels, leather soles, cleats or spikes. Make sure no stones are embedded in the soles.
- Keep all loose clothing, shoelaces, and towels away from moving parts.
- Do not reach into, or underneath, the unit or tip it on its side during operation.
- Do not allow other people to interfere in any way with the user or equipment during a session.
- Allow LCD consoles to “normalize” with respect to temperature for one hour before plugging the unit in and using.
- Use these products for their intended use as described in this manual. Do not use attachments that have not been recommended by the manufacturer.
- Keep the power cord away from heated surfaces. Do not pull the equipment by the power cord or use the cord as a handle. Do not run the power cord on the floor under or along the side of the Treadmill Desk. Refer to last assembly step for proper power cord routing.
- Never mount or dismount the Treadmill Desk while the walking belt is moving. In case of an emergency, such as tripping, grasp the desktop, and place the feet on the side platforms.
- Never walk or jog backwards on the Treadmill Desk.
- Do not use this product in areas where aerosol spray products are being used or where oxygen is being administered. Such substances create the danger of combustion and explosion.
- When it is necessary to immobilize the Treadmill Desk, press and hold both the SPEED DOWN ARROW and the PAUSE keys on the integrated user controls. Use the same sequence to mobilize the Treadmill Desk.
- Read all warnings on each product prior to starting a session.
- If warnings are missing or damaged, please contact Life Fitness immediately for replacement warning labels. Life Fitness is not responsible for missing or damaged warning labels.
- Health and Environmental Regulations Warning - This product may contain chemicals known to the State of California to cause cancer, birth defects, or other reproductive harm. For more information related to the European Commission Regulation (EC) No. 1907/2006 (REACH) and the California Safe Drinking Water and Toxic Enforcement Act of 1986 (Proposition 65), please visit <https://www.lftechsupport.com/web/guest/environmental-regulations-information>.

**SAVE THESE INSTRUCTIONS FOR
FUTURE REFERENCE.**

2 TREADMILL DESK DESIGN ILLUSTRATION

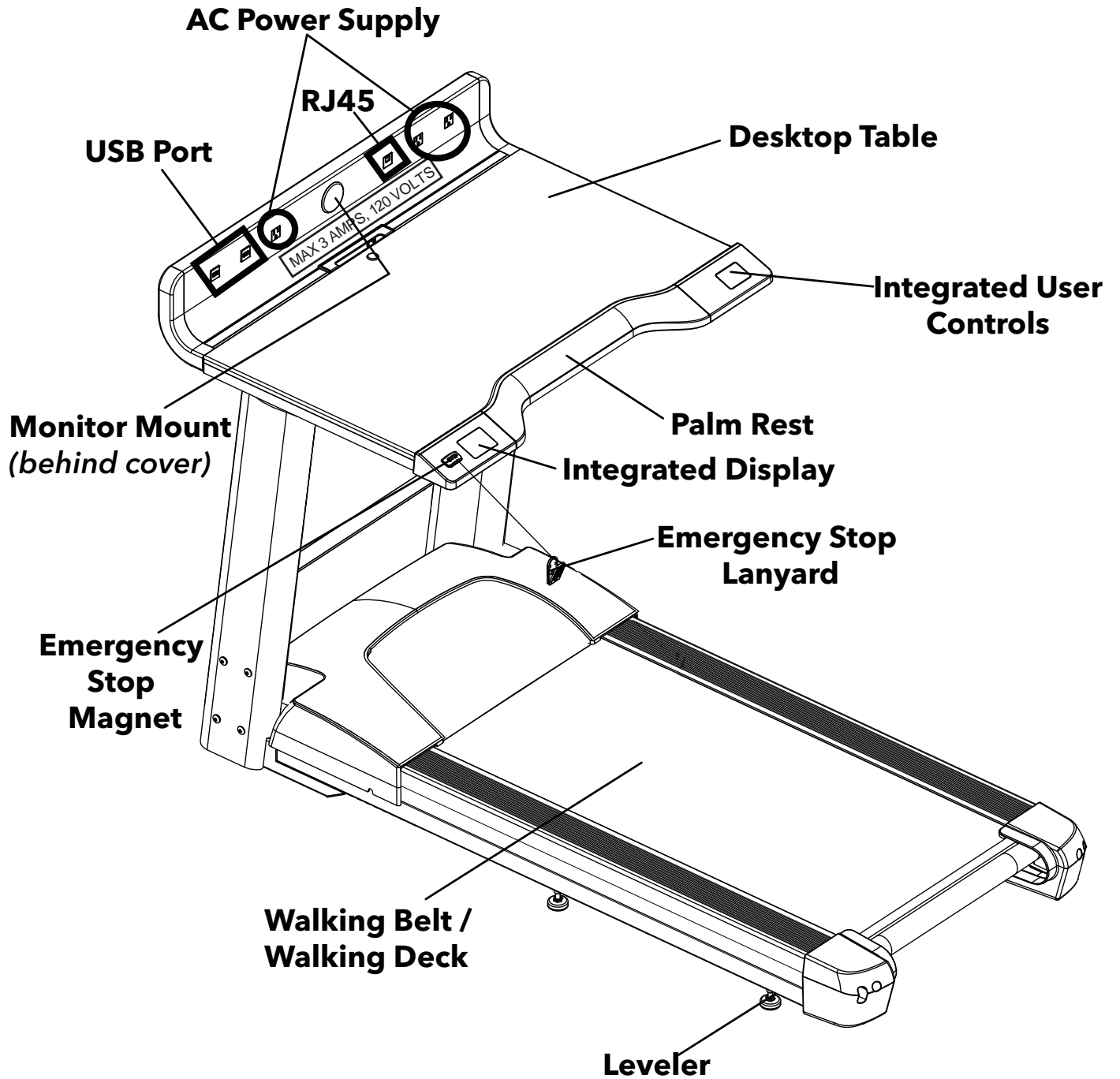

3 SETUP

Electrical Power Requirements

Below is a table that provides the current rating for this product based on supply voltage. Make sure that the Treadmill Desk supports the proper line voltage for the installation location before plugging into the outlet. Line voltage is noted on the product's serial label.

Supply Voltage (VAC)	Frequency (Hz)	Maximum Current (Amps)
120	60	12

Electrical Grounding Requirements

This product must be properly grounded. If the unit malfunctions or breaks down, proper grounding provides the path of least resistance for the electric current, which reduces the risk of shock to anyone touching or using the equipment. Each unit is equipped with an electrical cord, which includes an equipment grounding conductor and a grounding plug. The plug must be inserted into an outlet that has been properly installed and grounded in accordance with all local codes and ordinances. A temporary adapter must not be used to connect this plug to a two-pole receptacle in North America. If a properly grounded, correct amperage outlet is not available, a qualified electrician must install one.



A temporary adapter MUST NOT BE USED to connect this plug to a two-pole receptacle in North America. If a properly grounded, 15-amp outlet is not available, one must be installed by a qualified electrician. For use on a nominal 120-V circuit, this product has a grounding plug that looks like the one in the accompanying illustration. Make sure that the product is connected to an outlet having the same configuration as the plug.

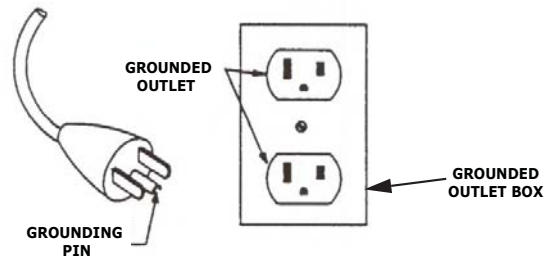

DANGER:

A risk of electrical shock may result from improper connection of the equipment's grounding conductor. Check with a qualified electrician if you are unsure about proper grounding techniques. Do not modify the plug provided with this product. If it will not fit an electrical outlet, have a proper outlet installed by a qualified electrician.

Power Switch

Located on the front panel at the base of the Treadmill Desk, the ON/OFF switch has two position - "I" (one) for ON and "0" (zero) for OFF.

Turning the Unit On

To turn the Treadmill Desk on, locate the ON/OFF power switch at the front of the Treadmill Desk near the power cord and turn it ON.

Where to Place the Treadmill Desk

Following all Safety Instructions in Section 1, move the Treadmill Desk to the location in which it will be used. See *Specifications* for the dimensions of the footprint. The ASTM International (ASTM) F2115 - 05 Standard recommends the minimum dimensions to be 1.64 ft. (0.5 m) on each side of the treadmill and 3.28 ft. (1 m) behind the rearward most portion of the usable moving surface

How to Stabilize the Treadmill Desk

After placing the unit where it will be used, check its stability. Thread all four levelers in completely. Level the unit using the two rear levelers. Bring the remaining two levelers down to contact the floor.

If there is even a slight rocking motion or the unit is not stable, determine which stabilizing leg is not resting on the floor. To adjust, loosen the JAM NUT (A) and turn the STABILIZING LEG (B) until the rocking motion ceases and both stabilizing legs rest firmly on the floor. Retighten the JAM NUT.

Note: *It is extremely important that the stabilizing leg be correctly adjusted for proper operation.*

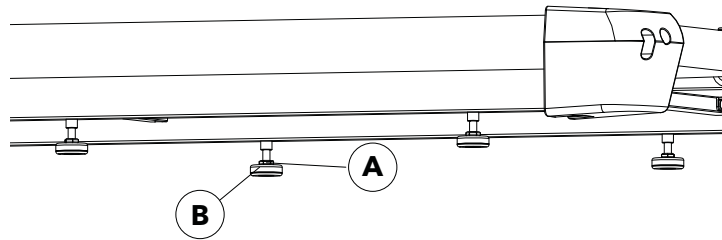

Checking the Belt

After the Treadmill Desk has been installed and stabilized, the belt must be checked to confirm proper tracking. First, ensure the power cord is plugged into a suitable outlet, as described in the above *Electrical Requirements* section. Then turn the Treadmill Desk on. Stand on the side rails of the Treadmill Desk and straddle the belt. To start the belt, press the GO key, then press the SPEED UP arrow key until the Treadmill Desk reaches 2.0 mph/ 3.2 kph. If the walking belt appears off-center, see the instructions in *Tracking (Centering) An Existing Or New Walking Belt (Section 8.4)*.

Note: *Normal belt operating position is for the belt to be located within the belt travel position indicators on the motor cover (see illustration to the right). If the belt is not in this position, see Section 8.4.*

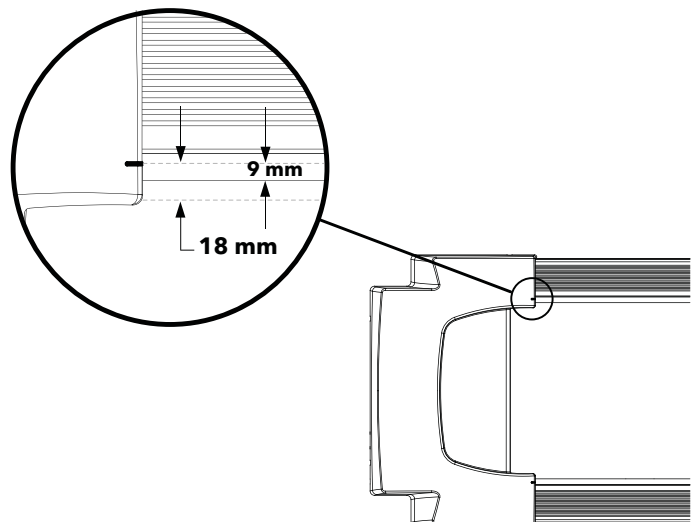

Moving the Treadmill Desk

Turn the Treadmill Desk off and disconnect its power cord.

Note: *If adjustments were made to the levelers during setup, make sure to tighten the levelers snug against the base frame before moving.*

The Treadmill Desk may now be moved on its front platform wheels by raising the back of the product and pushing / pulling. Do not attempt to move the Treadmill Desk by pushing or pulling on the deck, uprights, or desktop.

Immobilizing the Treadmill Desk “≡≡≡≡≡”

When it is necessary to immobilize the Treadmill Desk, press and hold both the SPEED DOWN ARROW and the PAUSE keys on the integrated user controls. Use the same key sequence to mobilize the Treadmill Desk.

How to Calibrate the Treadmill Desk

ATTENTION

Before using your treadmill please follow the calibration instructions below. Please stand to the side of your treadmill during calibration.

1. Turn the treadmill on.
2. Press and hold down the PAUSE key and then press the STOP Key while in idle mode. The display will beep consecutively three times and display the text “diAg” in the Time Window.
3. Press the GO key to view the Diagnostic Menu.
4. Use the SPEED UP and DOWN keys to scroll through the choices to “CAL”.
5. Press GO to select “CAL”.
6. Press the GO key to start Auto Calibration.
7. While the Time display shows “PrESS”, Distance and Steps windows shall show Software Version and checksum respectively.
8. After Calibration is performed, the Time window shall display “CAL” and the Steps window shall show “PASS” or “FAiL”

***If a failure occurred press the STOP key and restart the process at Step 2.

***If a failure occurs again take note of the error number display and contact Life Fitness customer support at 1-800-351-3737.

9. Press the STOP key to exit the test/information mode.
10. Press the STOP key to return to normal operation.

4 INTEGRATED CONSOLE DISPLAY & USER CONTROLS

The integrated display is located on the left hand side of the desktop ledge and shows the following session data:

- A. **Time:** Current session duration
- B. **Speed:** Current speed
- C. **Distance:** Distance walked
- D. **Steps:** Number of steps taken

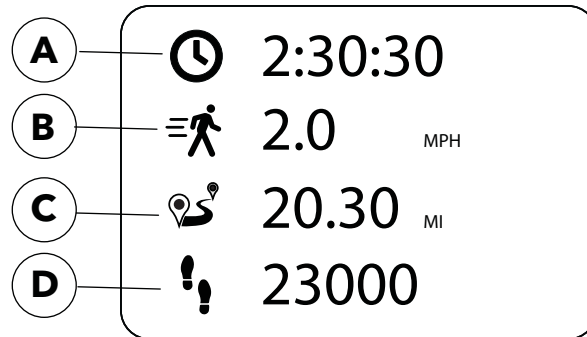

Session results will be displayed for 2 minutes after the STOP button is pressed or after 10 minutes of being paused.

Emergency Stop Magnet (E-Stop)

The rectangular magnet connects to the E-Stop Lanyard, which must be clipped to the user's clothing when the Treadmill Desk is in use. Pulling the lanyard so that it comes free of the magnet will stop the walking belt. This serves as a safety feature, stopping the belt should the user stumble or fall.

Note: The E-Stop Magnet must be attached before the walking belt and desktop height actuators are allowed to move. Removing the E-Stop Magnet stops the walking belt and desktop height actuators. All the parts remain electrically energized. In case of electrically caused errors, remove the power cord from the electrical outlet.



User Controls

The user controls are located on the right hand side of the desktop ledge and control the following basic operations of the Treadmill Desk:

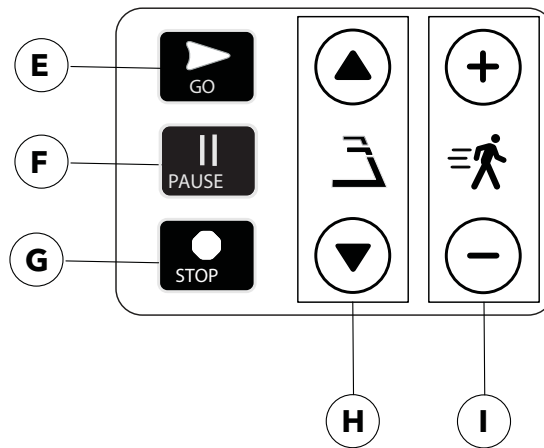

- E. **GO:** Press to begin moving the belt at 0.3 mph and start a session.
- F. **Pause:** Press to pause the walking belt and the session. The GO key will blink during PAUSE mode. The console displays a 10 minute countdown during Pause mode. Press the GO key to resume session. Press the STOP key to stop session. The session will end if no keys are pressed during the 10-minute Pause Mode. The console displays a 3-2-1 countdown when a session is resuming from Pause mode.
- G. **Stop:** Press once to stop the session and slow the belt to a gradual stop. Press twice to clear session data.
- H. **Raise / Lower Desktop Height:** Press to change the desktop height gradually, raising (UP ARROW) or lowering (DOWN ARROW) the desk height. Desktop height ranges from 36 in. - 48 in. (914.4 mm - 1219.2 mm) above the walking belt.
- I. **Increase / Decrease Speed:** Press to change the belt's speed gradually, increasing ("+" button) or decreasing ("-" button) the speed by 0.1 mph each time the buttons are pressed.

5 BACK LEDGE CONNECTION & ATTACHMENT OPTIONS

The Back Ledge of the Treadmill Desk provides the user with several connection and attachment options.

- A. **USB Ports (Quantity: 2)**
Max Power 2.1 Amps
- B. **AC Power Receptacles (Quantity: 3)**
Note: Total power for back ledge connections is 3 Amps 120 Volts.
- C. **RJ45 Ethernet Cable Receptacle (Quantity: 1)**

- D. **Monitor Mounting Attachment:**
Remove the round cover in the center of the back ledge to attach optional single or dual monitor mounting arms used to support the weight of the monitor(s).

- E. **Monitor Clamp:** Location for an Optional Monitor clamp to hold a monitor in place while Dynamic Desk is in use.

- F. **Cable Routing:** Convenient space to route cords from electronics placed on the desktop.

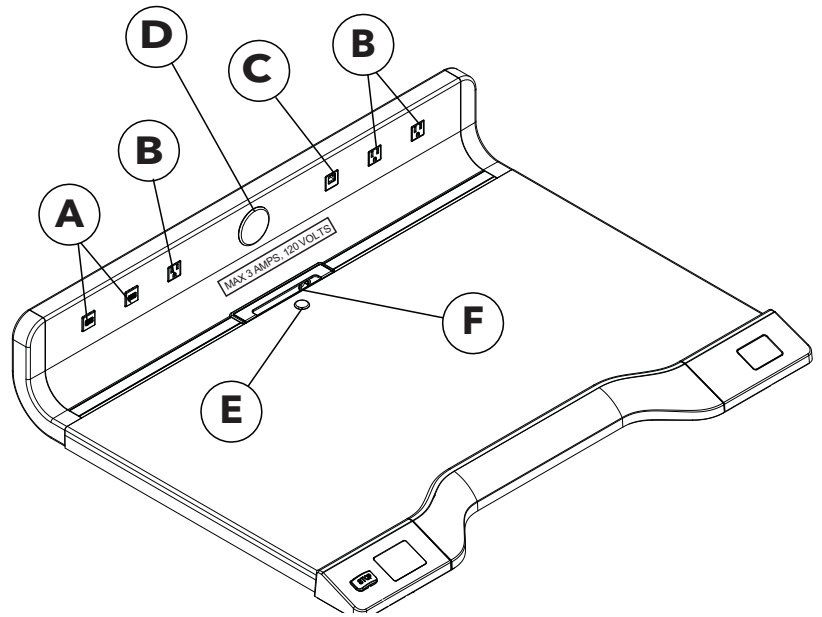

- G. **Optional PC/Tower Storage:** The right, underside of the desk can accommodate this option.

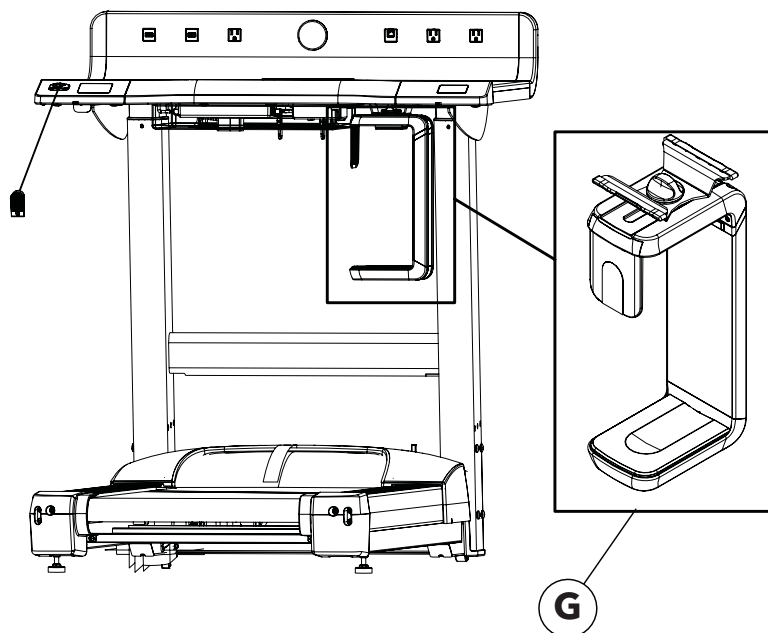

6 ERGONOMICS

Posture Recommendations

The body was designed to spend extraordinary amounts of time in a neutral posture. Here are some tips to help you maintain the best neutral posture while at the Treadmill Desk:

1. Chest should always remain open with shoulders back and the upper arms should be kept close to the body.
2. Use an ergonomic keyboard that keeps the hands further apart and thumbs higher than pinkies. Position the back (furthest point from user) of the keyboard higher than the front of the keyboard. Wrists should not be pronated (turned down). Wrists should also rest comfortably to prevent swaying.
3. The mouse should be located as close as possible to the body.
4. Using a monitor is highly recommended. Ensure you can see the entire monitor by shifting your eyes, but not tilting your head. Center the display so that the top edge of the monitor is at 0 degrees, and the bottom display is on a -15 degree sight line from your eyes. It is also generally recommended that the monitor is at arm's length from the user.



7 SETTINGS & DIAGNOSTICS MENUS

ENTERING SETTINGS MENU

Press and hold down the STOP key and SPEED DOWN ARROW key for three plus seconds. The display will beep consecutively three times and display the text "SEt" in the Time Window.

Press the GO key to enter the UNITS and MAXIMUM SPEED setting.

Press the PAUSE key to toggle between UNITS and MAXIMUM SPEED.

Press the SPEED UP and DOWN keys to change setting.

Press the STOP key to exit the SETTINGS MENU.

Setting	Default	Description
Maximum Speed	2 mph (3.2 kph)	The Time Window shall display "SPEEd" when the maximum speed setting is selected. Speed Range is 0.3 to 4.0 mph (0.48 to 6.4 kph).
Units	MPH & MI	The Time Window shall display "Un" when the Unit Setting is selected. Options for Speed are MPH or KM/H. Options for Distance are MI or KM.

ENTERING DIAGNOSTICS MENU

Press and hold down the PAUSE key and press the STOP key while in Idle Mode. The display will beep consecutively three times and display the text "diAg" in the Time Window.

Press the GO key to view the Diagnostic Menu.

Use the SPEED UP and DOWN keys to scroll through the following choices:

- Display Test (disP)
- Safety Switch Test (E-StOP)
- Calibration / Software Version (CAL)
- Key Test (q tESt)
- Usage Information / Statistics (StAt)

Press the GO key to select choice and enter selected test mode.

Press the STOP key to exit the test / information mode.

8 SERVICE AND TECHNICAL DATA

8.1 Troubleshooting

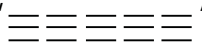
Problem	Cause / Solution
The Treadmill Desk does not turn on when the ON/OFF switch is turned on.	<i>You may be in "Energy Saver Mode". Press the GO button to see if the user controls turn on.</i>
	<i>Check to see if the Treadmill Desk is plugged in and if the ON/OFF switch is on. If the ON/OFF switch is on, verify that the Treadmill Desk power cord is not damaged and the wall outlet is functioning (tripped breaker).</i>
	<i>If the ON/OFF switch is on verify that all the customer assembly connections are working properly. Unplug and re-plug each connection to verify. Look to see if any of the cables were pinched during assembly.</i>
The GO button is lit and blinking. All other displays are blank / off.	<i>You are in "Energy Saver Mode". Press the GO button to wake up the user controls.</i>
The Treadmill Desk shakes a lot when I walk on it.	<ol style="list-style-type: none"> <li data-bbox="488 821 1435 852">1. <i>Turn the Treadmill Desk OFF. Make sure all assembly hardware is tightened.</i> <li data-bbox="488 884 1511 947">2. <i>If shaking still occurs, adjust the levelers under the stationary frame until the shaking decreases. See How to Stabilize the Treadmill Desk (Section 3).</i>
The belt is tracking to the left or right.	<i>See How to Adjust and Tension the Walking Belt (Section 8.3).</i>
The belt seems to slip when I walk on it.	<i>You may need to tighten the walking belt. See How to Adjust and Tension the Walking Belt (Section 8.3).</i>
I am having problems bolting the parts together when assembling the unit.	<ol style="list-style-type: none"> <li data-bbox="488 1167 1468 1230">1. <i>Do not fully tighten the screws until the crossbar, desktop, and uprights are all installed.</i> <li data-bbox="488 1262 1019 1293">2. <i>Check the screw threads for any damage.</i>
"-----" is displayed on the console.	<p data-bbox="488 1335 1349 1367"><i>This message is displayed if the Emergency Stop magnet is not in place.</i></p> <p data-bbox="488 1398 902 1430"><i>Place the magnet back in position.</i></p>
"  "	<i>This message appears in the Time display when the unit is immobilized. Press and hold both the SPEED DOWN ARROW and the PAUSE keys on the integrated user controls to mobilize the Treadmill Desk.</i>

8.2 Preventive Maintenance Tips

Note: Safety of the equipment can be maintained only if the equipment is examined regularly for damage or wear. Keep the equipment out of use until defective parts are repaired or replaced.

Remarque: pour conserver un matériel sûr, il convient de l'inspecter régulièrement afin de déceler tout signe d'usure ou d'endommagement. N'utilisez pas l'appareil tant que les pièces défectueuses n'ont pas été réparées ou remplacées.

The following preventive maintenance tips will keep the Treadmill Desk operating at peak performance:

IMPORTANT: TURN the Treadmill Desk OFF and UNPLUG PRIOR to PERFORMING ANY MAINTENANCE!	
WEEKLY	<i>Inspect the power cord. If the cord is damaged call technical support. Make sure the cord is positioned in a location where it will not be damaged.</i>
	<i>Check the operation of the Emergency Stop Magnet.</i>
	<i>Check the operation of the Stop Key.</i>
	<i>Check the position (centering) of the walking belt.</i>
MONTHLY	<i>Vacuum around and under the walking belt. It is normal for there to be some black dust behind the unit from the walking belt.</i>
	<i>Clean the display console and all exterior surfaces with mild soap, water and a soft cotton cloth or use a Life Fitness approved cleaner (see Life Fitness Approved Cleaners). Note: Do not use paper towels, ammonia or acid based cleaners on the product. At no time should cleaner be applied directly to any part of the equipment; spray the cleaner on a soft cloth and then wipe the unit.</i>
	<i>Inspect the exterior parts for wear and check the user assembly bolts are tight.</i>

Other servicing should be performed by an authorized service representative.

Life Fitness Approved Cleaners (United States Availability Only)

Two preferred cleaners have been approved by Life Fitness reliability experts: PureGreen 24 and Gym Wipes. Both cleaners will safely and effectively remove dirt, grime and sweat from equipment. PureGreen 24 and the Antibacterial Force formula of Gym Wipes are both disinfectants that are effective against MRSA and H1N1. PureGreen 24 is available in a spray which is convenient for gym staff to use. Apply the spray to a microfiber cloth and wipe down the equipment. Use PureGreen 24 on the equipment for at least 2 minutes for general disinfection purposes and at least 10 minutes for fungus and viral control. Gym Wipes are large, durable pre-moistened wipes to use on the equipment before and after sessions. Use Gym Wipes on the equipment for at least 2 minutes for general disinfection purposes. Please contact Life Fitness Customer Service at 1-800-351-3737 or email: customersupport@lifefitness.com.

Life Fitness Compatible Cleaners

Mild soap and water or a mild non-abrasive household cleaner can also be used to clean the display and all exterior surfaces. Use a soft microfiber cloth only. Apply the cleaner to the microfiber cloth before cleaning. DO NOT use ammonia or acid based cleaners. DO NOT use abrasive cleaners. DO NOT use paper towels. DO NOT apply cleaners directly to the equipment surfaces.

8.3 How to Adjust and Tension the Walking Belt on the Treadmill Desk

Do not move the Treadmill Desk or place hands under the Treadmill Desk while it is plugged into an electrical outlet!

Tools Required: 6mm Hex Key Wrench

Belt Tensioning Bolts

The Treadmill Desk has access holes in the rear roller guards, which allow access to the tensioning bolts. These tensioning bolts make it possible to adjust tracking and centering of the walking belt (A) without removing the guards.

Note: It is extremely important that the Treadmill Desk be correctly leveled prior to any tracking adjustments. An unstable unit may cause walking belt misalignment. See How to Stabilize the Treadmill Desk in Section 3 prior to attempting any rear roller adjustments.

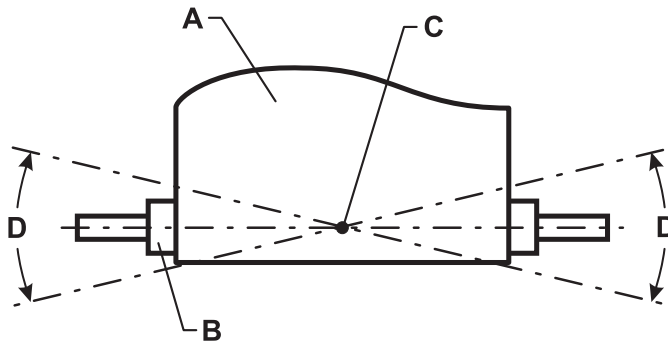

Before proceeding, it is helpful to visualize the REAR ROLLER (B) PIVOT POINT (C). Each adjustment made to one side of the Roller must be met with an equal and opposite adjustment (D) to the other side of the Roller to maintain an ideal belt tension at the pivot point.

Tensioning an Existing Walking Belt

Under normal usage, the walking belt may stretch slightly. If the belt starts to slip during use, take the steps listed below to correct the tension.

1. Using the STOP key, stop the Treadmill Desk.
2. Turn the belt tensioning bolts clockwise a quarter-turn per side to tension the belt. Do not exceed one full turn (four quarter-turns per side).
3. Set the Treadmill Desk at 2.0-mph (3.2 kph) and get on to make sure the belt no longer slips. Also, check the walking belt's tracking. If the walking belt drifts to the left or right see *Tracking (Centering) an Existing or New Walking Belt*.

Note: Do not over-tighten the tensioning bolts while making belt adjustments. Over-tightening of bolts may over stretch and damage the walking belt or roller bearings. Do not exceed one full turn of either bolt in either direction.

8.4 Tracking (Centering) an Existing or New Walking Belt

1. Locate the two access holes to the belt tensioning bolts (A) on each of the rear roller guards.
2. Stand on the sides of the Treadmill Desk and straddle the belt. Press GO and set the belt speed to 2.0 mph. (3.2 kph)
3. If the walking belt has moved to the right, turn the right tension bolt 1/4 turn clockwise with the provided 6mm hex key wrench, and then turn the left tension bolt 1/4 turn counter-clockwise to start walking belt tracking back to center of roller.
4. If the walking belt has moved to the left, turn the left tension bolt 1/4 turn clockwise and then turn the right tension bolt 1/4 turn counter-clockwise to start walking belt tracking back to center of roller. Repeat adjustments until the walking belt appears centered. Allow the machine to continue running for several minutes to observe if tracking remains stabilized.

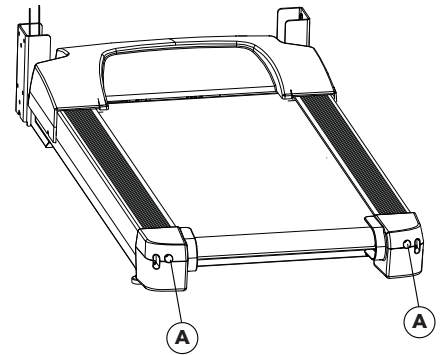

Note: Do not exceed one full turn of the adjusting screws in either direction. If after one full turn the belt does not track properly, contact Customer Support Services.

8.5 Using and Testing the Safety Stop Pull Cord

During operation of the Treadmill Desk, the lanyard on the Safety Stop pull cord should be attached to an item of the user's clothing.

While the Treadmill Desk is ON and the console display is active remove the Safety Stop pull cord from the Treadmill Desk. A message shall be displayed on the console similar to "- - - - -". With the Safety Stop pull cord removed no keys shall function on the Treadmill Desk.

8.6 How to Obtain Product Service

1. Please contact Life Fitness Customer Service at 1.800.351.3737.
2. Verify the symptom and review the operating instructions and troubleshooting matrix.
3. Locate and document the serial numbers on the Treadmill Desk (*located on the front base frame; user's left*). Please have proof of purchase information available.

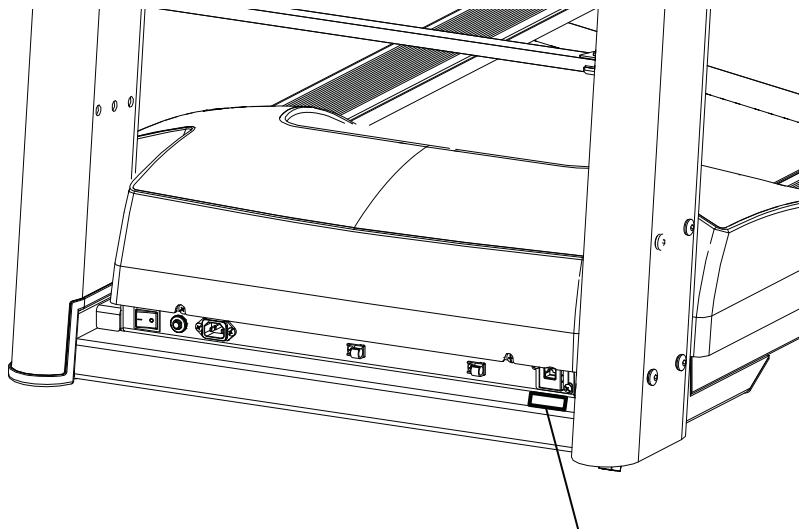

Base Serial Number Label

9 SPECIFICATIONS

Designed Use:	Commercial / Consumer
Maximum User Weight for Treadmill:	350 lbs. / 159 kg
Maximum Load Dynamic Weight for Desktop:	100 lbs. / 45.36 kg
Speed Range:	0.3 - 4.0 mph (0.48 - 6.4 kph) in 0.1 increments Default: 2 mph (3.2 kph)
Adjustable Height Range:	36 in. - 48 in. (91.44 cm - 121.92 cm) above walking belt
Step-up Height:	7 in. (17.78 cm)
Motor:	3 HP continuous duty DC
Rollers:	Front: 2.6 in. (6.7 cm) precision crowned Rear: 2 in. (5 cm) precision crowned
Belt:	48 in. (121.9 cm) Length x 19.75 in. (50.165 cm) Width, multi-ply
Deck:	Flex Deck cushioning, not reversible
Power Specifications:	Back Ledge: 2 USB Ports: 2.1 Amps 3 AC Power Receptacles: 3 Amps 120 Volts Power Strip underneath desktop: 2 Amps 120 Volts
Warranty:	7 years, frame 3 years motor, mechanical and electrical parts 1 year labor & wear parts

PHYSICAL DIMENSIONS (ASSEMBLED OUT OF BOX)				
	Length	Width	Height	Weight
Treadmill Desk	71 in. (180.3 cm)	40 in. (101.6 cm)	49 in. (124.46 cm)	279 lbs. (126 kg)

	SHIPPED (PACKAGED) DIMENSIONS			
	Length	Width	Height	Weight
Box 1: Base Frame	53.6 in. (183.2 cm)	33 in. (84 cm)	12.6 in. (32 cm)	152 lbs. (69 kg)
Box 2: Desktop & Uprights	52.95 in. (134.5 cm)	35.8 in. (91 cm)	15 in. (38 cm)	186.29 lbs. (84.5 kg)

10 WARRANTY

7 Years	3 Years	1 Year
<ul style="list-style-type: none"> • Frame 	<ul style="list-style-type: none"> • Drive Motor • Electrical Parts • Mechanical Parts 	<ul style="list-style-type: none"> • Labor • Wear Parts (<i>walking belt, drive belt, deck, rollers</i>)

WHAT IS COVERED:

This Life Fitness commercial product ("Product") is warranted to be free of all defects in material and workmanship.

WHO IS COVERED:

The original purchaser or any person receiving a newly purchased Product as a gift from the original purchaser. Warranty will be voided on subsequent transfers.

HOW LONG IS IT COVERED:

All coverage is provided by specific Product according to the guidelines listed on the chart above.

WHO PAYS SHIPPING & INSURANCE FOR SERVICE:

If the Product or any warranted part must be returned to a service facility for repairs, Life Fitness will pay all shipping and insurance charges during the warranty period (within the United States only). The purchaser is responsible for shipping and insurance charges after the warranty has expired.

WHAT WE WILL DO TO CORRECT COVERED DEFECTS:

We will ship to you any new or rebuilt replacement part or component, or, at our option, replace the Product. Such replacement parts are warranted for the remaining portion of the original warranty period.

WHAT IS NOT COVERED:

Any failures or damage caused by unauthorized service, misuse, accident, negligence, improper assembly or installation, debris resulting from any construction activities in the Product's environment, rust or corrosion as a result of the Product's location, alterations or modifications without our written authorization or by failure on your part to use, operate and maintain the Product as set out in your User Manual ("Manual"). All terms of this warranty are void if this Product is moved beyond the continental borders of the United States of America (excluding Alaska, Hawaii and Canada) and are then subject to the terms provided by that country's local authorized Life Fitness Representative.

WHAT YOU MUST DO:

Retain proof of purchase. Use, operate and maintain the Product as specified in the Manual; notify the place of purchase of any defect within 10 days after discovery of the defect; if instructed, return any defective part for replacement or, if necessary, the entire Product for repair. Life Fitness reserves the right to decide whether or not a product is to be returned for repair.

USER MANUAL:

It is VERY IMPORTANT THAT YOU READ THE MANUAL before operating the Product. Remember to perform the periodic maintenance requirements specified in the Manual to assure proper operation and your continued satisfaction.

PRODUCT REGISTRATION:

Register online at www.lifefitness.com/home/product-registration.html. Our receipt assures that your name, address and date of purchase are on file as a registered owner of the Product. Being a registered owner assures coverage in the event you lose your proof of purchase. Please retain your proof of purchase, such as your bill of sale or receipt.

HOW TO GET PARTS & SERVICE:

Refer to page one of this manual for your local service contact information. Reference your name, address and the serial number of your Product (consoles and frames have separate serial numbers). They will tell you how to get a replacement part, or, if necessary, arrange for service where your Product is located.

EXCLUSIVE WARRANTY:

THIS LIMITED WARRANTY IS IN LIEU OF ALL OTHER WARRANTIES OF ANY KIND EITHER EXPRESSED OR IMPLIED, INCLUDING BUT NOT LIMITED TO THE IMPLIED WARRANTIES OF MERCHANTABILITY AND FITNESS FOR A PARTICULAR PURPOSE, AND ALL OTHER OBLIGATIONS OR LIABILITIES ON OUR PART. We neither assume nor authorize any person to assure for us any other obligation or liability concerning the sale of this Product. Under no circumstances shall we be liable under this warranty, or otherwise, of any damage to any person or property, including any lost profits or lost savings, for any special, indirect, secondary, incidental or consequential damages of any nature arising out of the use of or inability to use this Product. Some states do not allow the exclusion or limitation of implied warranties or of liability for incidental or consequential damages, so the above limitations or exclusions may not apply to you. Warranties may vary outside the U.S. Contact Life Fitness for details.

CHANGES IN WARRANTY NOT AUTHORIZED:

No one is authorized to change, modify or extend the terms of this limited warranty.

EFFECT OF U.S. STATE LAWS:

This warranty gives you specific legal rights and you may have other rights which vary from state to state.